



# MAX PROP

AUTOMATIC FEATHERING PROPELLERS

## Instruction Manual

---

### EASY / WHISPER

*3, 4 & 5 Blades*



Scan the QR code  
with a mobile  
device to view the  
installation video.

## 1) INTRODUCTION:

Thank you for having chosen a MAX PROP® automatic feathering propeller for your vessel. This instruction booklet is designed to answer all your questions on installation and use of the Max-Prop. Please read it carefully and verify the correct working of the propeller before installing it on your boat.

## 2) INSTALLATION:

The propeller is supplied already assembled for right or left rotation, according to the information received at order and with the pitch required if discussed at the time of the order, and is therefore ready to be fitted on the shaft. MAX PROP® parts are NOT interchangeable. Make sure, if you receive more than one propeller, that you do not interchange parts.

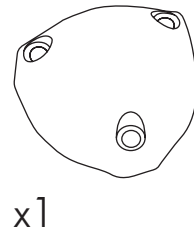
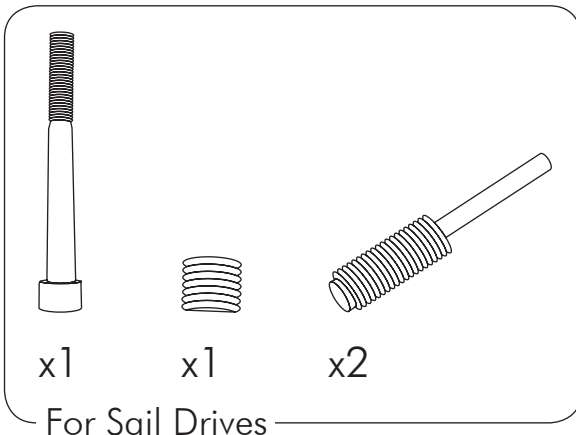
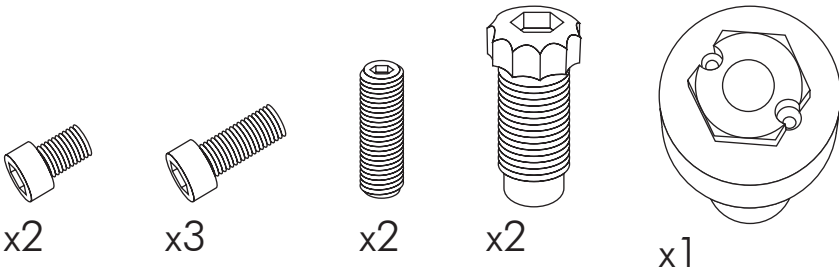
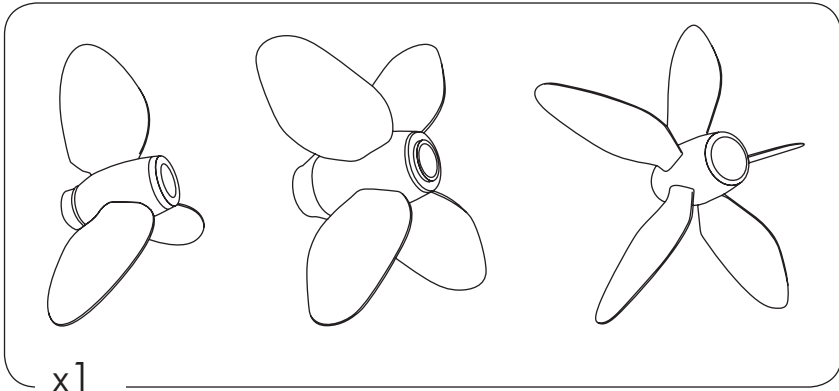

- A) Fit the MAX PROP<sup>®</sup> onto the propeller shaft, like a fixed propeller, and be sure that the key is proper dimension: A properly fit key has almost no clearance side to side but a very small clearance on its upper surface. This clearance is to avoid the propeller being pushed off center by a key which is too tall.

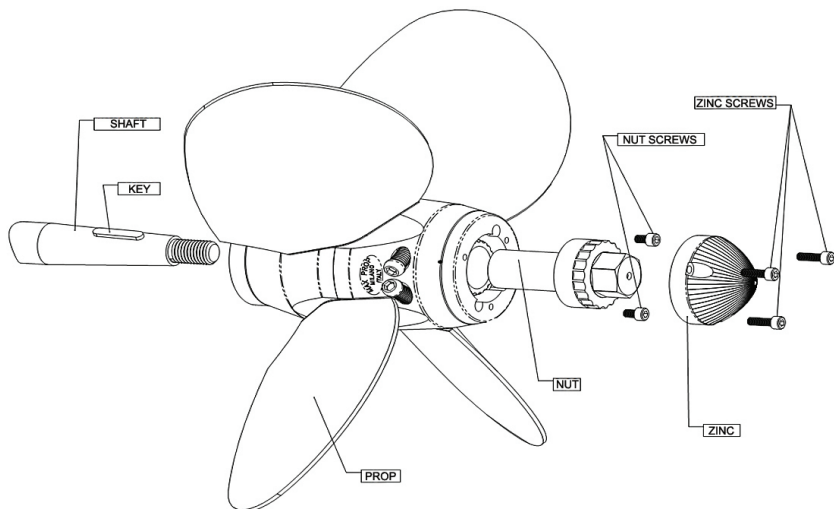
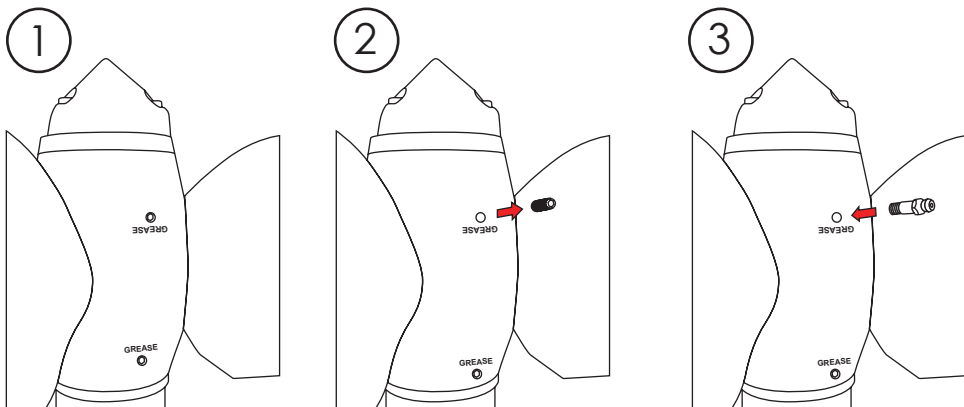
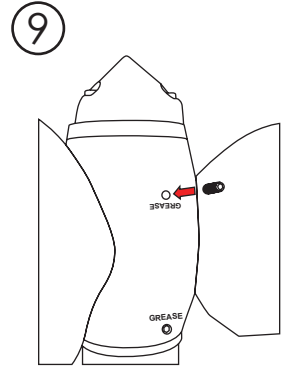
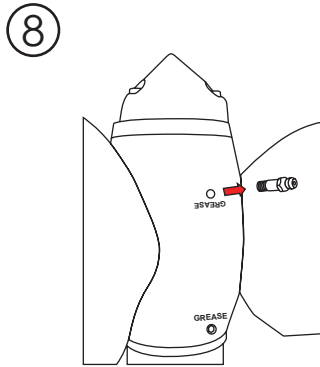
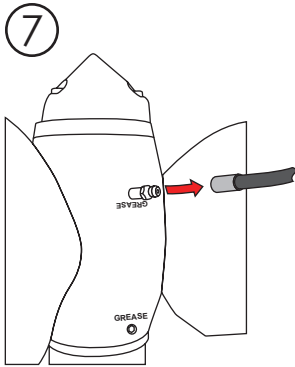
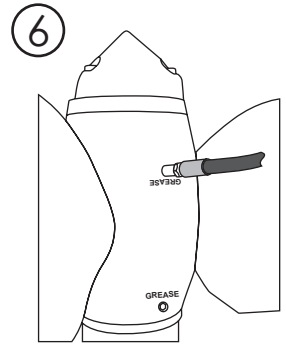
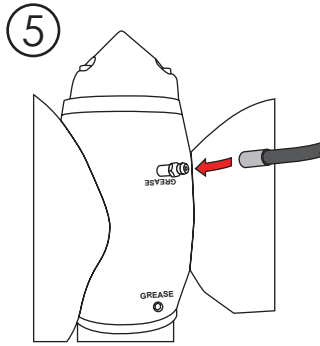
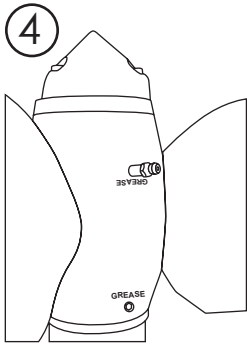

Fig.1

- B) Tighten the nut and secure it in place using the two allen head screws. For a Sail Drive only next tighten the center bolt and secure it with the set screw through the side.
- C) Fit the zinc and secure it with the three allen bolts. Make sure that the zinc and the propeller are clean to insure good contact.
- D) Fill the prop with marine grease (supplied) using a grease fitting (supplied) inserted into the grease holes on the side of the propeller marked "GREASE". The MAX PROP<sup>®</sup> EASY propeller works properly only if the central body is completely filled with the correct grease. Verify that the grease is oozing from the rotating joints between the central part and the hub, so that all of the moving surfaces are perfectly greased. The grease used must be a type of grease approved by MAX PROP<sup>®</sup> so it will remain fluid after years of use and will not get too stiff in cold water.





\* Then repeat with the forward fitting.

E) Move the blades into the feathered position, making sure that the rounded trailing edges of the blades are aft as shown in Fig. 2

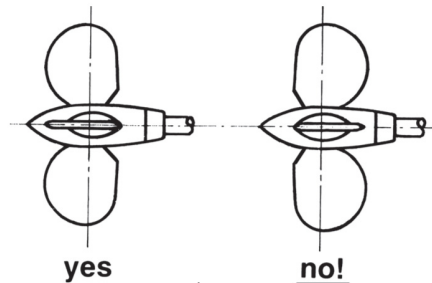

Fig.2

F) Before launching the boat, it is absolutely necessary to operate as follows:

- Hold the propeller shaft.
- Check that the blades of the propeller rotate freely from the forward to the reverse position just by a light effort.
- In the feathered position the blades must be perfectly lined up and set like Fig. 2.
- Check that the propeller body is full of fluid marine grease.
- Make sure that the propeller is protected from galvanic corrosion by using zinc anodes on the propeller and the shaft.

### 3) PITCH ADJUSTMENT:

The pitch on a MAX PROP® changes according to the diameter and the blades rotation angle. Fig. 3 shows the pitch in inches corresponding to the degree of blades angle for a given propeller diameter.

		Propeller Diameter														
		12"	13"	14"	15"	16"	17"	18"	19"	20"	21"	22"	23"	24"	25"	26"
Blade Angle	10°	4	4.3	4.6	4.9	5.2	5.5	6	6.3	6.7	7.1	7.4	7.7	8	8.3	8.6
	12°	4.8	5.2	5.6	6	6.4	6.8	7.2	7.6	8	8.4	8.8	9.2	9.6	10	10.4
	14°	5.6	6	6.6	7.1	7.6	8	8.4	8.8	9.4	9.8	10.4	10.8	11.2	11.6	12.2
	16°	6.4	6.9	7.6	8.1	8.6	9.1	9.8	10.3	10.8	11.3	12	12.5	13	13.5	14
	18°	7.2	7.8	8.6	9.2	9.8	10.4	11	11.5	12.1	12.8	13.4	14	14.6	15.2	16
	20°	8.2	8.9	9.6	10.3	11	11.6	12.4	13	13.7	14.5	15	15.6	16.4	17	17.8
	22°	9.2	10	10.7	11.4	12.2	12.9	13.6	14.3	15.1	16	16.8	17.5	18.2	18.9	19.8
	24°	10	10.9	11.8	12.5	13.4	14.2	15	15.8	16.8	17.6	18.4	19.2	20.2	21	21.8
	26°	11	12	12.8	13.8	14.7	15.7	16.6	17.4	18.4	19.3	20.2	21	22	22.9	23.8
	28°	12	13	13.9	15	16	17	18	18.9	20	21	22	23	24	25	26
30°	13	14	15.1	16.2	17.3	18.5	19.6	20.6	21.7	22.8	24	25	26.1	27.3	28.2	

Fig.3

Inches of Pitch

Diameter and pitch must be calculated as if MAX PROP® EASY was a normal fixed propeller. MAX PROP® EASY then offers the great advantage of pitch adjustability in order to optimize the performance of the propeller. If the engine does not reach the desired RPM, reduce the blade angle; on the contrary, if the engine exceeds the desired RPM, increase the blade angle.

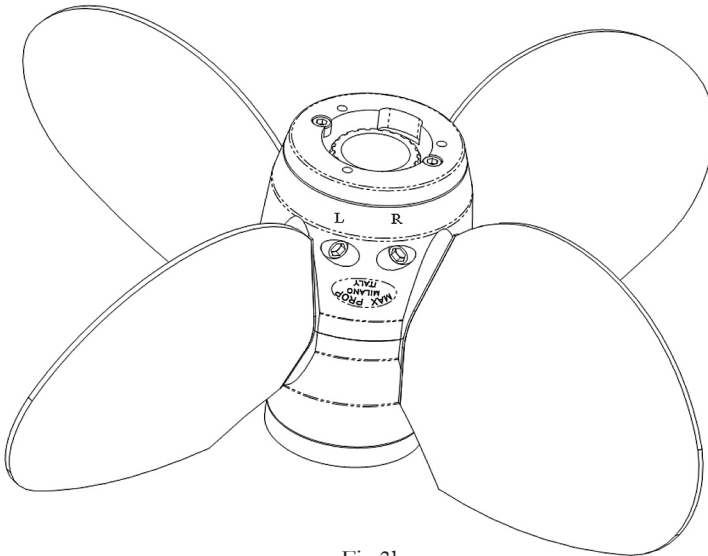

Fig.3b

## PITCH ADJUSTMENT *Continued*

The MAX PROP® EASY allows an angle variation of 2 degree increments, this corresponds to a variation in the engine RPM of about 13% at the same boat speed. It's possible to change either the pitch to optimize the engine performance, or the rotation (for ex. if you change the engine, or if there were a mistake when ordering the prop). If you have doubts about the rotation: shaft rotation is determined from the stern of the boat looking forward. With the engine in forward position clockwise rotation of the propeller means it is right hand "R", and a counterclockwise rotation is a left hand "L".

Pitch and rotation of the MAX PROP® EASY can be changed as follows:

On the body of the propeller are two threaded bores, marked with letters "R" and "L"; within these bores are placed two bolts.

The pitch of the propeller, both in front and reverse position, can be easily varied by changing the supplied bolts threaded into the body of the propeller with other bolts of a different length.

The pitch in forward rotation varies changing the bolts placed in bore "R" if the propeller is right-handed or changing the bolts placed in bore "L" if the propeller is left-handed. The list of the pitch regulation bolts, that are supplied with every EASY propeller is indicated in fig. 4

For example inserting the #20 bolt in the forward rotation and 2 in the reverse rotation will provide a 20 degree angle for both front position and reverse rotation. Varying 1 millimeter the length of the bolts, blades inclination has a 2 degrees variation

Fig.4

Blade Angle Degrees	Right Rotation		Left Rotation	
	Forward Bore "R"	Reverse Bore "L"	Forward Bore "L"	Reverse Bore "R"
16	16	1	16	1
18	18		18	
20	20	2	20	2
22	22		22	
24	24	3	24	3



Close up of the Left and Right pitch adjustment bolts.

Fig.5

## CHANGING THE ROTATION

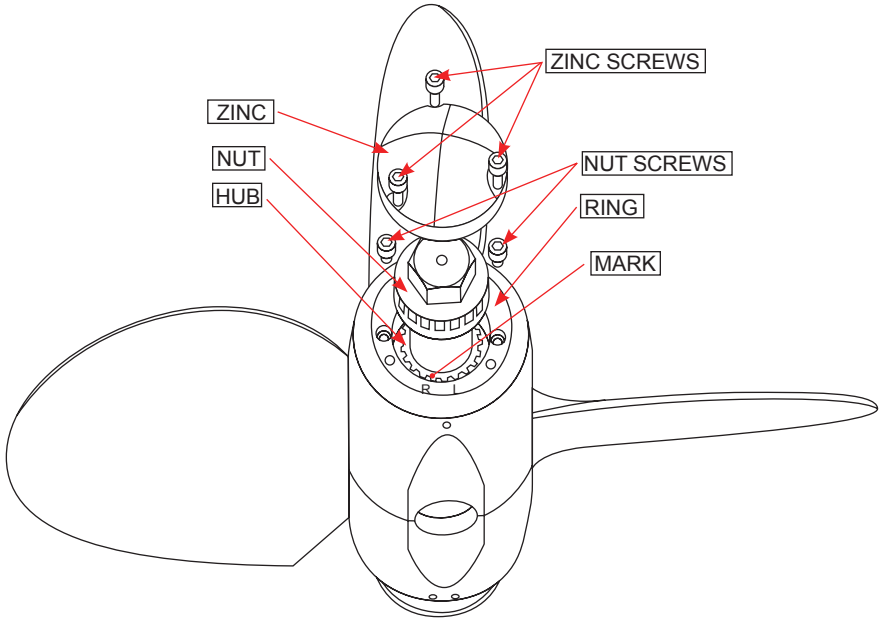

Fig.6

With the MAX PROP EASY® it is also possible to change the rotation, e.g. if you change the engine, or if there was a mistake when ordering the prop. If you have doubts about the engine rotation, it can be determined looking forward from the stern of the boat. With the engine in forward position a clockwise rotation of the propeller means it is right handed (R), and a counter-clockwise rotation is left handed (L). In order to change the rotation of the MAX PROP EASY®, from a right hand rotation to a left hand rotation or vice versa do as follows, referring to fig.6

1. Place the propeller in the feathered position. Unscrew the locking-zinc screws, and remove the zinc
2. Unscrew the locking-nut screws and remove the nut
3. Remove the Circlip on the aft edge of the hub
4. Be sure the propeller is in the feathered position, then release the zinc-bearing ring
5. Once released the zinc-bearing ring, you see that on one tooth of the hub (the aft side) there is a reference mark, and a tooth of the bearing-zinc ring are marked one with "L" and the other with "R".
6. If you place the zinc bearing ring in its seat again, matching the "L" tooth with the hub reference mark, you have a left hand rotating propeller, on the contrary, with the "R" tooth you have a right rotating propeller as in fig.6
7. Replace the "Circlip" in to its seat
8. Tighten the nut and secure it with the locking-nut screws
9. Place the zinc again, and secure it with the 3 proper screws
10. Be sure to change the pitch setting bolts to reflect the pitch setting for the new rotation.

#### 4) **PROPELLER USE:**

---

The MAX PROP® EASY works automatically. By putting the transmission in gear the blades will engage in either forward or reverse (WARNING: do not change from forward to reverse and vice versa when the engine is running at high RPM ) and feathers from forward position when you turn off the engine and lock the shaft.

The best way to feather the propeller is:

- Power at 2 to 3 knots in forward.
- Kill the engine while still engaged in forward.

If your propeller has been greased properly it will feather in a fraction of a second as soon as you stop the shaft from freewheeling. **DO NOT** kill the engine while in reverse. In this case the blades will be in the reverse position and cannot feather. You can actually use this feature to drive a shaft alternator.

Modern transmissions are either mechanical or hydraulic. With a mechanical transmission, the best way to stop the shaft freewheeling is to engage the transmission in reverse ( WARNING: engage the reverse only after the engine has stopped completely). With a hydraulic transmission you must shut off the engine while still engaged in forward. The remaining hydraulic pressure will in effect lock the shaft for a few moments, enough for the MAX PROP® to feather.

#### 5) **MAINTENANCE:**

---

- The propeller must always be completely filled with recommended grease, the propeller should be greased at least once a year.
- Make sure that you always keep the zinc anodes in good condition. They must be replaced at least once a year, even if they still look ok. The propeller must be protected by a lot of zinc, so also use a zinc on the shaft when possible. When replacing it make sure that you clean the surfaces between the zinc and the propeller shaft in order to have a good electrical contact.

#### **WARNING:**

It is important to follow the instruction below carefully so as to avoid a shock load to the gears on the blades and cone gear, that could be damaging to the teeth.

- When going from forward to reverse and the opposite, it is necessary to idle down and shift at low RPM's between gear, that could be damaging to the teeth.

#### 6) **PROPELLER REMOVAL:**

---

In order to remove the propeller you must first remove the zinc and remove the nut. Next fit a long armed gear puller over the front of the propeller as show in fig. 7. Tightening the center bolt of the gear puller will release the MAX PROP® from the propeller shaft.

If the bolt from the gear puller is not long enough to contact the end of the propeller shaft inside the MAX PROP® the MAX PROP® nut can be loosened and left in place. In this scenario the bolt from the puller will push against the back of the nut to release the propeller from the shaft.

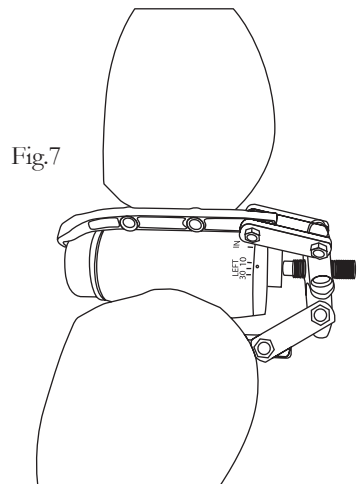



## 7) **INSTRUCTIONS FOR THE PROPER FITTING OF A NEW LOCKING NUT OF THE PROPELLER FIG.8**

If the Locking Nut needs to be replaced it will need to be fit to the propeller as follows. With a new propeller the Locking Nut received with the propeller has already been machined to fit correctly.

1. When it's locked on the motor shaft, the nut must contact the 3 surfaces S1, S2, S3. Therefore, if a new nut has to be machined you must be sure that length L1 and L2 coincide precisely with the corresponding lengths of prop hub, and that length L3 is greater than the length of the threaded edge of motor shaft. To check that the work is done properly, you just have to spread a very thin coat of Prussian blue on the 3 surfaces S1, S2, S3. Insert then the nut in its seat in the hub and let the nut rotate softly in relation to the hub, with a light pressure. When this is done, the 3 surfaces of the hub must be painted in blue.
2. When fitting the prop on the motor shaft, it's necessary to check that the threaded part of the motor shaft doesn't touch the threaded end of the nut. Also, when the nut is tight, the blades rotation on their axis does not get hard. In case the blades rotation movement becomes hard, you have to remove from surface S1 a very small amount of material. This operation can be done simply by using a flat smooth file.

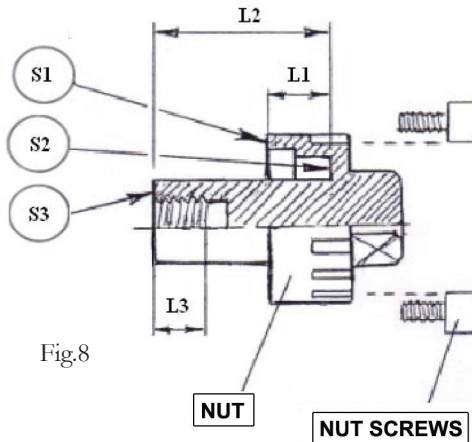

## 8) **SPECIAL NUT (FIG.9) ONLY FOR MAX PROP WITH ANTI-SHOCK DEVICE FOR SAIL DRIVE**

Unlike the standard nut, this kind of nut, when it's locked on the motor shaft, must lean **ONLY** to surfaces S1 and S2 and is secured by 4 devices: 2 threaded pins, and a central screw with a dowel. When you mount the propeller on the motor shaft the same nut checking is necessary as previously described for fig. 8.

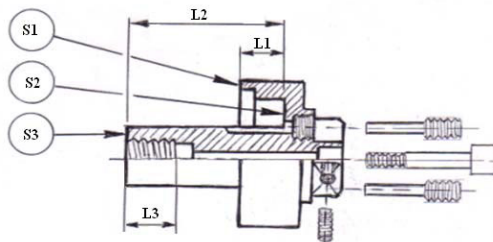



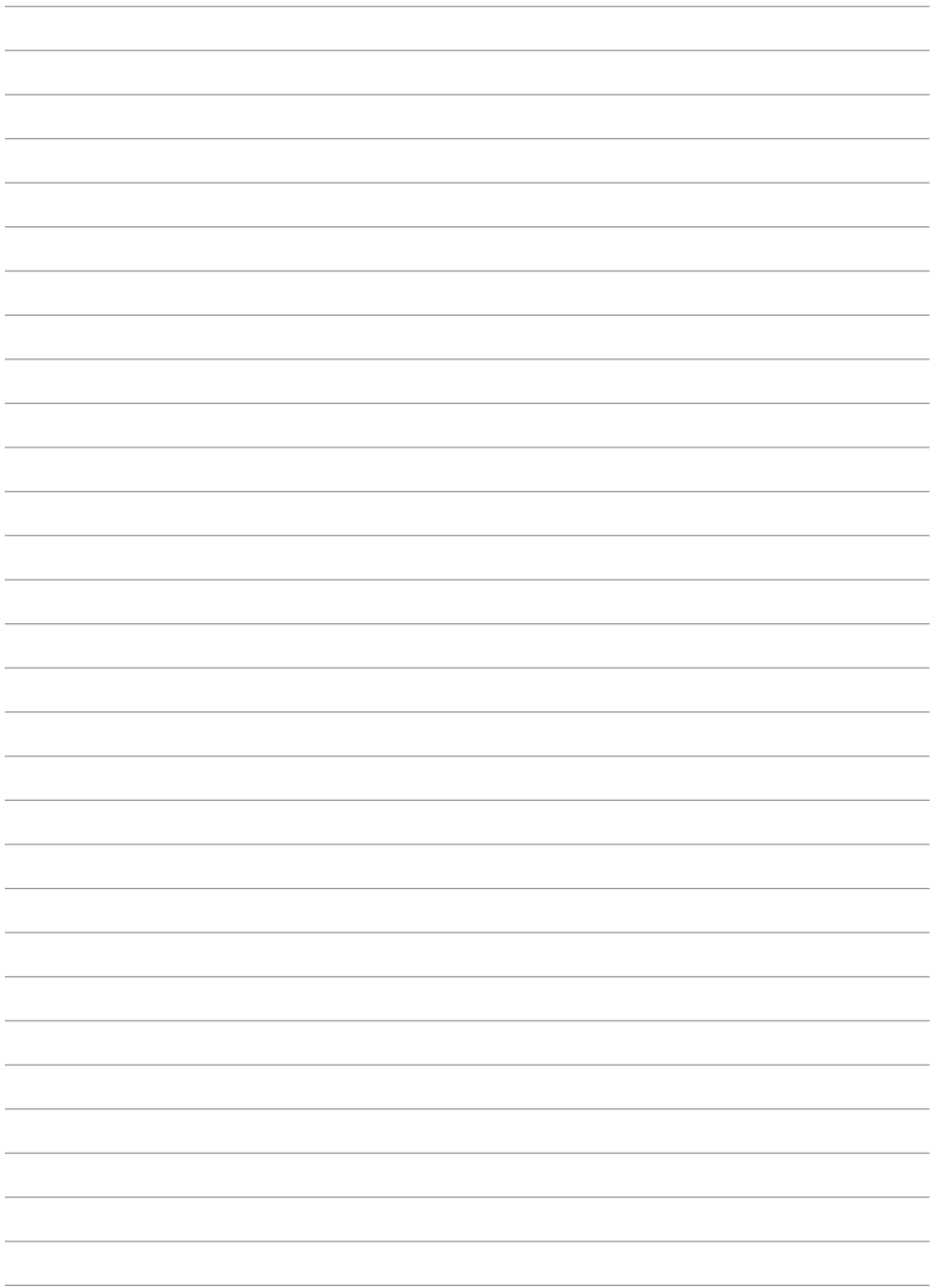

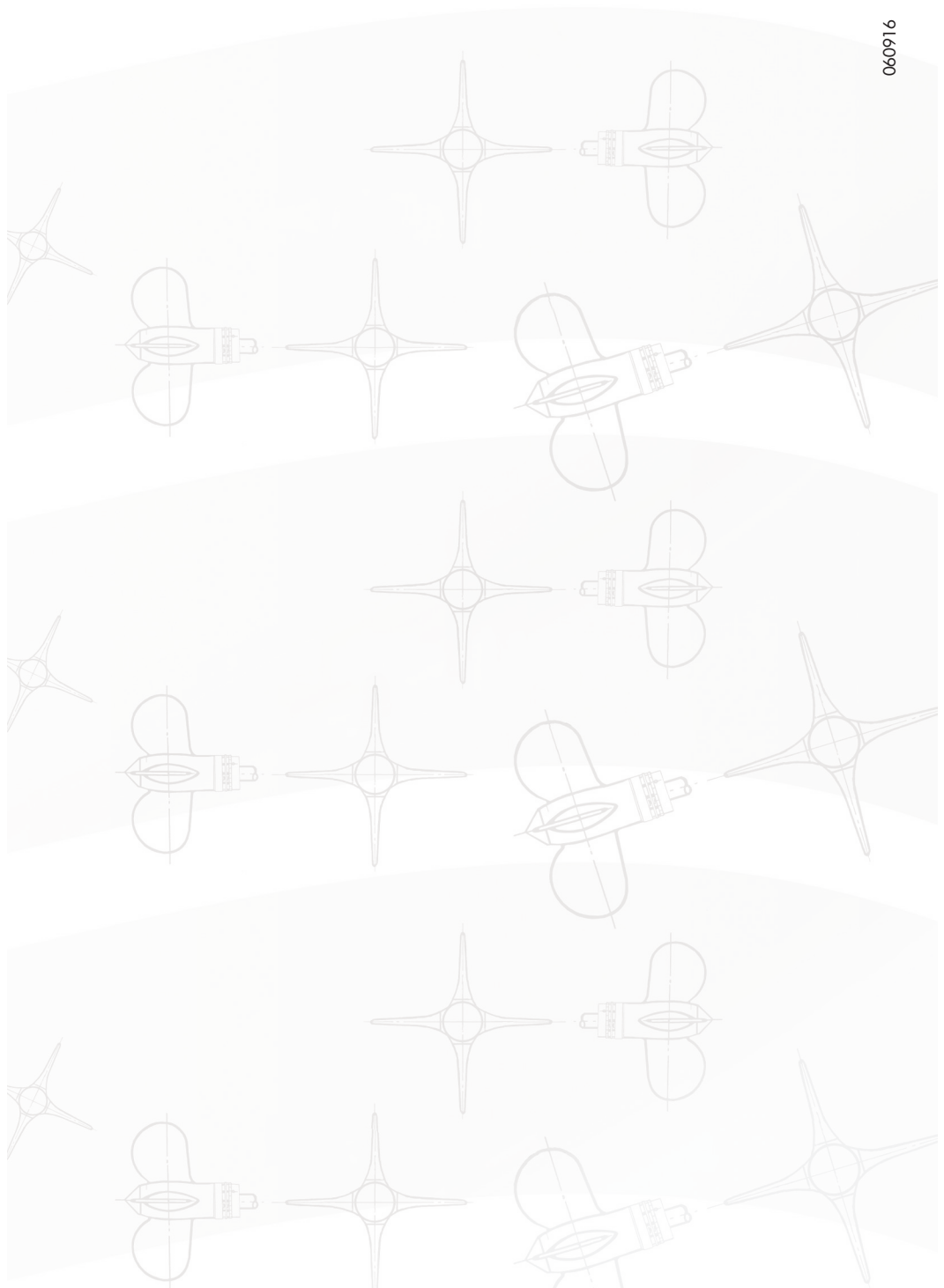

**MAX PROP PATENTED PROPELLERS**

PYI Inc., 12532 Beverly Park Rd., Lynnwood, WA 98087

Tel: 425-355-3669 Fax: 425-355-3661 [info@pyiinc.com](mailto:info@pyiinc.com) [www.max-prop.com](http://www.max-prop.com)