

simpson-lawrence

# sprint

400 WINDLASS

operation & maintenance instructions

## contents

---

- |                              |                           |
|------------------------------|---------------------------|
| 1. Exploded Diagram          | 7. Joining Rope to Chain  |
| 2. Planning the Installation | 8. Maintenance            |
| 3. Accessories               | 9. Dismantling Procedures |
| 4. Specification             | 10. Troubleshooting       |
| 5. Installation              | 11. Warranty              |
| 6. Operating Instructions    |                           |

**This Manual forms part of the Product and MUST BE RETAINED along with, OR incorporated into, the Owner's Manual for the vessel to which the Windlass is fitted.**



400

1. Exploded Diagram Model #0060400

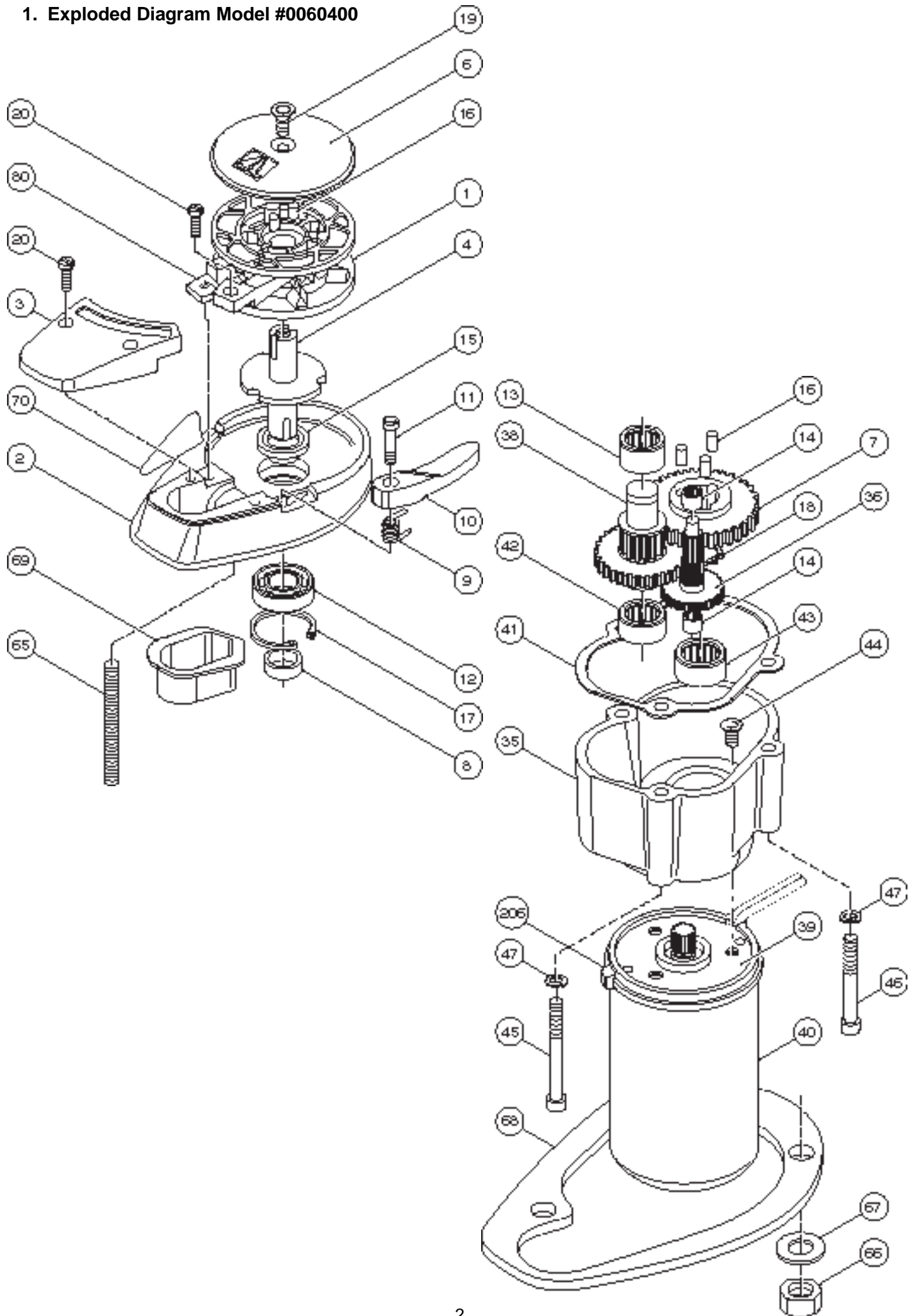

## 1. Parts List

Item No.	List Number	S-L USA Part Number	Description	Qty.
1	60529G6	AA60529RC061E	6 Pocket Rope/Chain Gipsy	1
2	605-002	AA6060502E	Baseplate	1
3	605-003	AA6060503E	Baseplate Cover	1
4	605-004	AA6060504E	Mainshaft	1
6	605-006	AA6060506E	Gipsy Drive Cap	1
7	605-007	AA6060507E	Mainshaft Gear	1
8	605-008	AA6060508E	Mainshaft Spacer	1
9	6060509	AA6060509E	Torsion Spring	1
10	6060510	AA6060510E	Control Arm	1
11	605-011	AA6060511E	Control Arm Shoulder Screw	1
12	529-016	AA6052916E	Ball Bearing	1
13	529-015	AA6052915E	Needle Roller Clutch	1
14	605-014	AA6060514E	Needle Roller Bearing	2
15	*		Seal	1
16	6044518	AA6044518E	Drive Roller	5
17	529-026	AA6052926E	Internal Circlip	1
18	529-027	AA6052927E	External Circlip	1
19	529-022	AA6052922E	Counter Sunk Socket Screw	1
20	605-020	AA6060520E	Cheese Head Screw	3
35	605-035	AA6060535E	Gear Case	1
36	6060536	AA6060536E	1st Compound Gear	1
38	6060538	AA6060538E	Compound Gear Assembly	1
39	*		12v Electric Motor	1
40	*		Motor Cover	1
41	*		Gasket	1
42	605-042	AA6060542E	Needle Roller Bearing	1
43	529-014	AA6052914E	Needle Roller Bearing	1
44	529-020	AA6052920E	Counter Sunk Socket Screw	3
45	605-045	AA6060545E	Socket Head Cap Screw	1
46	531-042	AA6053142E	Socket Head Cap Screw	2
47	526-063	AA6052663E	Lock Washer	3
65	445-023	AA6044523E	Mounting Studs	3
66	445-026	AA6044526E	Nut	3
67	445-030	AA6044530E	Washer	3
68	605-068	AA6060568E	Clamping Plate	1
69	605-069	AA6060569E	Chain Pipe Sleeve	1
70	604-070	AA6060470E	Nameplate	1
80	6060580	AA6060580E	Rope/Chain Fleming	1
81	6065081	AA6065081E	Chain Only Fleming	1
206	*		Cable Tie	2

\* Forms part of a kit listed below

List Number	S-L USA Part Number	Description
6060590	AA6060590E	Seal and Gasket Kit (Item # 15 and 14)
6060591	AA6060591E	Above Deck Unit
6060592	AA6060592E	Below Deck Unit
6060594	AA6060593E	Motor Cover Kit (Item # 40 and 206)
6060595	AA6060595E	Motor and Cable Tie Kit (Item # 39, 40 and 206)

## WELCOME

Congratulations on becoming a proud owner of a **Simpson-Lawrence** Windlass. You can take confidence in being among men and women who have depended on our products for over 90 years. **Simpson-Lawrence** is known throughout the World as *Manufacturers of Quality Marine Equipment*. Our factory manufactured anchoring components, anchor rodes, bow rollers and anchors, are specifically engineered to compliment one another. To ensure that we serve you in the best manner possible, we offer a complete range of anchoring systems to meet all of your needs.

### ***For Your Safety*** **Read Before Installing and Operating Your Windlass**

Classification Societies and Simpson-Lawrence require that a vessel at anchor must have its rode held by a chain stopper or equivalent strong point at all times!

At all times it is the responsibility of the boat user to ensure that the anchor and rode are properly stowed for the prevailing sea conditions. This is particularly important with high-speed powerboats, because an anchor accidentally falling in the water while under way can cause considerable damage. An anchor windlass is mounted in the most exposed position on a vessel and is thus subject to severe atmospheric attack resulting in a possibility of corrosion in excess of that experienced with most other items of deck equipment. As the windlass may only be used infrequently, the risk of corrosion is further increased. It is essential that the windlass is regularly examined, operated and given any necessary maintenance.

\*\*\*\*\*

## 2. PLANNING the INSTALLATION

### 2.1 Gipsy Suitability

The RC061 rope/chain gipsy is ideally suited to our factory made anchor rodes, which consist of rope spliced to a chain tail. Rope used with this rope/chain gipsy must be windlass grade, ½" (12-14mm) medium lay three strand nylon. Ropes from different manufacturers have wide variations in stretch and consistency in diameter. Therefore, rope and chain from other manufacturers may require some experimentation to determine the optimum size. On **NO** account should multiplait ropes be used!

¼" American ACCO BBB or ¼" American G-4 ISO (7mm) should be chosen to suit your gipsy. Should you have difficulty in matching a gipsy to your chain please consult your local agent or our International Network of Simpson-Lawrence distributors worldwide.

### 2.2 Package Contents

Windlass  
Mounting Studs, Nuts, Washers and Clamping Plate  
Safety Instructions  
Mounting Template  
Instruction Booklet  
Breaker/Isolator  
Control Switch

### 2.3 Additional Requirements

Each windlass installation requires:

#### WINDLASS INSTALLATION

- a. An appropriate marine sealant
- b. The following tools:
  - 3/8" (10mm) Diameter Drill
  - 2" (50mm) Diameter Hole Saw
  - ½" (13mm) Wrench
  - File
  - Jig Saw or Trepanning Tool

## WIRING INSTALLATION

Flat Bladed Screwdriver  
Crimping Pliers/Wire Stripper  
Suitable electrical cable and crimp terminals.

### 2.4 Electric Cable Selection

To achieve the best performance and safeguard your electrical system it is essential that any electrical windlass be fitted with sufficiently large diameter cable to cope with the current draw imposed upon it and to keep the voltage drop within acceptable limits. In any circumstance voltage drop due entirely to cable resistance should not exceed 10% for a 12V installation.

The following table gives recommended cable sizes. The recommendations are based on total length of cable required, from the battery, following the route of the cables.

***Total length of cable run is from the battery to the windlass, and from the windlass back to the battery.***

***DO NOT confuse cable Length with the length of the vessel!***

#### METRIC or STARTER CABLE

Cable Length (ft./m)	Size (mm <sup>2</sup> )
51.0ft/15.5m	6
58.0ft/17.7m	7
72.0ft/21.6m	8.5

#### AMERICAN CABLE

Cable Length (ft.)	Size (AWG)
44.0	10
73.0	8

*In Multi Station installations 14 AWG wire (1.5mm<sup>2</sup> cross sectional area, 21/0.30 PVC covered) is used to connect the switches to the reversing control box.*

## 3. ACCESSORIES

Use only genuine Simpson-Lawrence parts and accessories to ensure top performance and eliminate the risk of voiding your warranty. For additional accessories and replacement parts, please see your dealer or call Simpson-Lawrence.

25 Amp Breaker                      HM25BKR(0050713)

#### Single Station

Reversing Control Switch                      0052519

or

#### Multi Station Operation

Dual Direction Solenoid                      0052531

*With any of the following or the Switchgear marketed by Simpson-Lawrence UK and its International distributors throughout the world can also be used.*

Hand Held Remote Switch	QU1002
Black Covered Foot Switch	QU900/D
Black Covered Foot Switch	QU900/U
White Covered Foot Switch	QU900/D
White Covered Foot Switch	QU900/U
Remote Console Switch	HMCONSW (0052518)

## 4. SPECIFICATION

#### Performance

##### Maximum Load

Chain in Gipsy	440 lbs. (200 kg)
Rope in Gipsy	450 lbs. (204 kg)

## Typical Working Figures

LOAD lbs./kg	SPEED		AMPS
	ft./min	m/min	
55/25	70	21.3	17
110/50	60	18.3	35
220/100	46	14.0	54
330/150	25	7.6	72

Power Out	95	28.9	7
-----------	----	------	---

## 5. INSTALLATION

### 5.1 Fitting the Windlass to the Deck

If the deck is not flat, a suitable mounting pad may be required to take up camber or sheer. Decks that are thin, or of foam or balsa laminate construction, will require reinforcement in order to spread the loads that will be applied to the deck while the windlass is in use. Place the windlass on the deck and decide upon a position for it with reference to the vessel's stemhead roller and the chain locker below. Rode lead from the roller should ideally be fed horizontally back to the top of the gipsy and along its centerline. There must be sufficient vertical fall for the chain or rope, even with a full locker, to draw the rode from the gipsy when hauling in.

The standard M8 threaded mounting studs supplied suit deck and packing thickness of up to 3 1/8" (76 mm). These are adequate for most installations. Place the mounting template on the deck or mounting pad in the desired position for the windlass and hold it in place using adhesive tape. Using a 3/8" (9.5 mm) diameter drill, make the three holes for the mounting studs. With a 1 3/4" (44 mm) diameter hole saw, make the hole for the rode to pass through, then with a jig saw, remove the rest of the material from the inside of the inner thick line. To help avoid water absorption by the deck, apply an appropriate marine sealant to the freshly cut hole edges. When all the holes have been made, remove the template.

Fully screw the three mounting studs into the base of the windlass. This can be done, quite

simply, by screwing two nuts onto the opposite end. Put them close enough to one another to use the inner one as a lock nut. Use the outer nut to screw the nut into the case with the aid of the spanner or wrench. Do this to each of the nuts in turn and remove the nuts for later use.

Apply a suitable sealant (Do not use 5200) to the base of the windlass, any mount pad and around the studs. **DO NOT GET CAULK OR SEALANT UNDER THE GEARTRAIN COVER (ITEM # 3).** Secure the windlass firmly to the deck from below, using the nuts and washers supplied.

**Note:** If using silicone or other rubbery type sealant, it is advisable to allow curing of the sealant before final tightening of the mounting nuts.

### 5.2 Wiring

The wiring system should be of the two cable fully insulated return type, which avoids possible electrolytic corrosion problems. We recommend the use of type III stranded, tinned copper wire with copper crimp terminals. Most modern installations are negative return (negative ground) but polarity should be checked.

In a Multi Station installation, the reversing control box must be sited in a dry location. **Do not install the control box in the anchor locker.** If a control box is installed in an anchor locker it is exposed to harsh conditions it is not designed to withstand. Furthermore this type of installation will void your warranty.

Overload protection must be built into the windlass wiring circuit. This protects the wiring and prevents undue damage to the windlass motor, in the event of its being stalled by an excessive load in service.

It is advisable to site the circuit breaker in a dry, readily accessible place. Our recommended Breaker/Isolator must be manually reset should an overload occur that causes it to trip to the 'OFF' position.

**Note:** Crimp terminals should be used on all wire ends wherever possible for good electrical contacts.

### 5.3 Electromagnetic Compatability

It is essential that this product does not cause any electromagnetic disturbance to any other electrical or electronic equipment installed in the vessel. This will be achieved if the windlass is connected to the same battery as the vessel's starter motor and not to the service battery to which other equipment is connected. In addition, the run of the wiring, from the battery to the windlass, should be kept as far apart from the other wiring on the vessel as possible. For instance, if the main wiring loom is to starboard, fit the windlass wiring to port. It should be noted that there is no evidence to indicate that windlass installations do cause magnetic interference but the installer is advised to carry out checks when the installation is complete.

### 5.3 Control Switch Installation

Follow the mounting instructions supplied with the switch. Remember, in a Multi Station installation all switches must be wired in a parallel circuit.

## 6. OPERATING INSTRUCTIONS

As a prudent act of seamanship, anchor recovery operations require the undivided attention of skipper and crew to prevent personal injury or damage to the vessel. In a typical anchor recovery situation, the windlass will pass through a number of operational phases.

### 6.1 Safety First

To avoid personal injuries ensure that limbs, fingers and clothing are kept clear of the anchor rode and windlass during operation. Always ensure that there are no swimmers or divers nearby when dropping your anchor.

### 6.2 Letting Go

Release any independent anchor locks. If it is safe to do so, let go under power by operating a 'Down' control.

### 6.3 Lying to Anchor Safely

Vessels at anchor will snub on the rode and this can cause slippage or apply excessive loads to the windlass.

**For maximum safety and to prevent damage, the windlass must not be left to take the entire force from the anchor rode while at anchor.** The rode should be made fast directly to a bollard, sampson post or cleat.

### 6.4 Hauling In

Untie the bridle or replace the rode in the gipsy.

If it is safe to do so, operate an 'Up' control.

Having retrieved the anchor, ensure it is independently secured to prevent its accidental release.

## 6.5 Operating Tips

When anchoring, it is best to power the rode out, allowing the vessel to take up stern way before full scope is let out. This helps prevent the rode from becoming tangled on top of your anchor on the seabed.

To aid anchor recovery, we recommend that the vessel's engine be used to assist by moving the vessel towards the anchor. We do not recommend that the vessel be motored over and beyond the anchor, as this can cause the rode to damage your topsides.

As the anchor approaches the stemhead, the last few feet of rode should be inched in by judicious use of controls to avoid damage to the vessel.

Having retrieved the anchor, ensure it is independently secured to prevent accidental release. It is strongly advised to use an anchor safety strap (Part # HMSTRAP), or chain stopper.

When mooring stern to, at a suitable distance from the jetty, deploy the anchor to prevent the bow from swinging. Gently pay out the rode under the influence of the stern way of the vessel as it approaches the jetty. Make fast your vessel with warps from the stern.

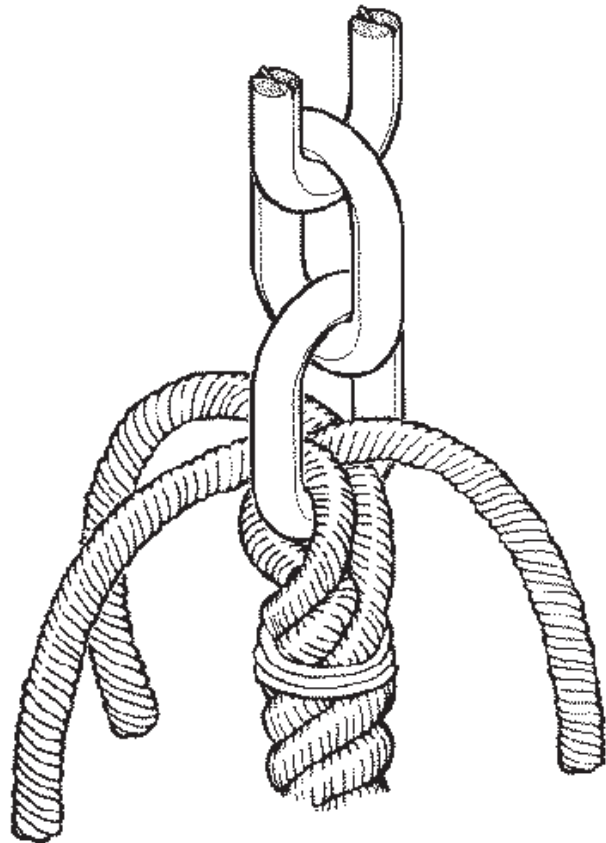

## 7. Joining Rope to Chain

When splicing rope to chain, select a length of chain that will avoid having the splice positioned in the gipsy when the anchor comes over the stemhead. Furthermore, ensure that the splice is no tighter than the rope. A hard splice is not desired.

With whipping twine or similar, seize your rope 8" from the rope's end and unlay the strands.

Pass one strand through the chain link from one side and the other two strands from the opposite side.

Remove seizing and complete a back splice in the normal manner for four full tucks.

With a hot knife pare down the three strands by one half of their diameter and continue with two further tucks.

With a hot knife, carefully melt the ends back into the line. Because of wide variations in rope type and construction some experimentation may be required.

Whip the line with permanent whipping at the beginning of the taper.

The above method of joining is designed to minimise chafe between the rope and chain but



as a matter of prudent seamanship the splice should be checked regularly and remade if there is any evidence of wear.

## 8. MAINTENANCE

### General Recommendations

Isolate the windlass electrically, before carrying out any maintenance work.

After the first two or three anchor recoveries, check the mounting nuts to ensure that the windlass is still fastened tightly to your deck, as it should now be 'bedded-in'.

Regularly wash down the exterior of your windlass with fresh water.

Examine all electrical connections for possible corrosion, clean and lightly grease as necessary.

Anchor rode splice should be checked regularly and remade if there is any evidence of wear.

The Gipsy (60526RC061) should be examined on a regular basis, because it is a high wear item. This Gipsy is designed for short scopes of chain and will last longer if properly used.

## 9. DISMANTLING PROCEDURES

### 9.1 Gipsy Replacement

Remove the Socket Screw (Item # 19), using a 5mm A/F Torque Key. Withdraw the Gipsy Drive Cap (Item # 6) and carefully set aside the two Stainless Steel Rollers (Item # 16).

Remove the Screws (Item # 20) that retain the Fleming (Item # 80) and the Baseplate Cover (Item # 3) using a flat bladed screw driver. Pull the Control Arm (Item # 10) outwards. Remove the Gipsy assembly. Open the Fleming and remove it from the gipsy. To replace a Gipsy, reverse the above procedure but apply a drop of **Loctite** to retain the Socket Screw (Item # 19) in the Mainshaft (Item # 4).

### 9.2 Control Arm Replacement

Remove Control Arm Shoulder Screw (Item # 11) to withdraw Control Arm (Item # 10). The Torsion Spring (Item # 9) can easily be withdrawn from within the Control Arm. To replace Control Arm reverse above procedure.

### 9.3 Mainshaft Replacement & Lubrication Service

**Note:** Lubrication and internal parts will not fall out when the windlass is disassembled. The geartrain and its bearings have been lubricated for you with **PFG 210** grease and should require no regular attention. PFG is a white synthetic grease containing PTFE. Use grease of a similar specification throughout. It is recommended that the above deck components be stripped, cleaned and re-greased at least annually. To do this, the gipsy with its Fleming should be removed as detailed above. Inspect the Mainshaft Seal (Item #15) for signs of wear. If the seal is found to be unserviceable, the Mainshaft will have to be withdrawn and seal replaced. This entails removing the Gear case (Item #35) and its contents, using a 5mm Allen Wrench (Torque Key). Holding the Motor (Item #39) remove the Cap Screws (Item #45 and #46) and their Lock Washers (Item # 47), the lower the below deck assembly away. Remove the External Circlip (snap ring (Item #18)) and withdraw the Mainshaft Gear (Item #7). Take care to retain the three Drive Rollers (Item #16) and the Mainshaft Spacer (Part #8). The Mainshaft can now be withdrawn above deck, with or without the Gipsy Assembly attached, provided the Fleming is no longer fixed to the Baseplate. Remove the seal and replace it with a new one. Clean the stripped down components in kerosene, dry them and inspect them for wear. Rebuild the windlass applying generous amounts of grease. Do not forget to grease around the Mainshaft Seal. Stick the Drive Rollers to the Mainshaft with grease. To reassemble, reverse the above procedure.

## 9.4 Electric Motor Replacement

**Isolate the windlass electrically!** Disconnect the Motor Cables from the vessel's wiring loom. Remove the Gear Case (Item #35) using a 5mm Allen Wrench (Torque Key) as detailed above. Remove the Compound Gears (Item #36 & #38) to allow access to the three Motor Mounting Screws (Item #44). Using a 3mm Allen wrench, remove the screws. Part the Motor from the Gear Case and cut through the Cable Ties (Item #206), remove the Motor Boot (Item #40 ). Ensure that there is a hole in the bottom of the boot. Replace the Motor by reversing the above procedure, using new cable ties to retain the Motor Boot in position. Use **Loctite** on the Motor Screws.

## 10. TROUBLESHOOTING

As with most electrical marine equipment the majority of problems that arise are electrical in nature. Therefore it is essential that the proper voltage be maintained. The proper voltage on a 12 volt system is 13.5 volts. (Constant low voltage will destroy the motor). Ensure that electrical cable size is large enough to handle the current draw imposed upon it and to keep the voltage drop within acceptable limits. In any circumstance voltage drop due entirely to cable resistance should not exceed 10% for 12 volt installation.

Follow the charts to trouble shoot the problem.

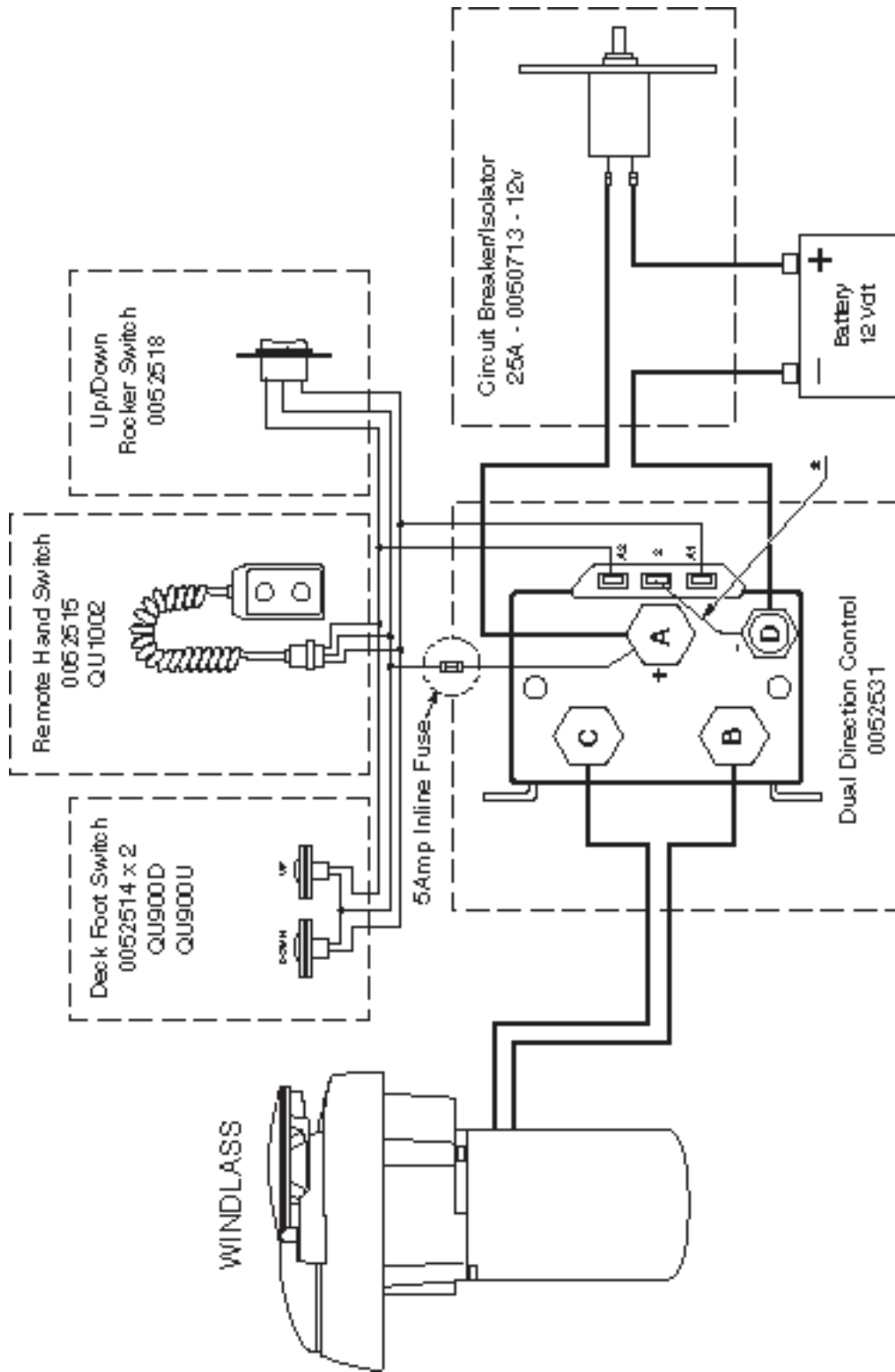

\*Dual Direction Control is supplied with jumper wire to connect the negative terminal D to terminal 2. This provides a ground circuit for the Dual Direction Control relay.

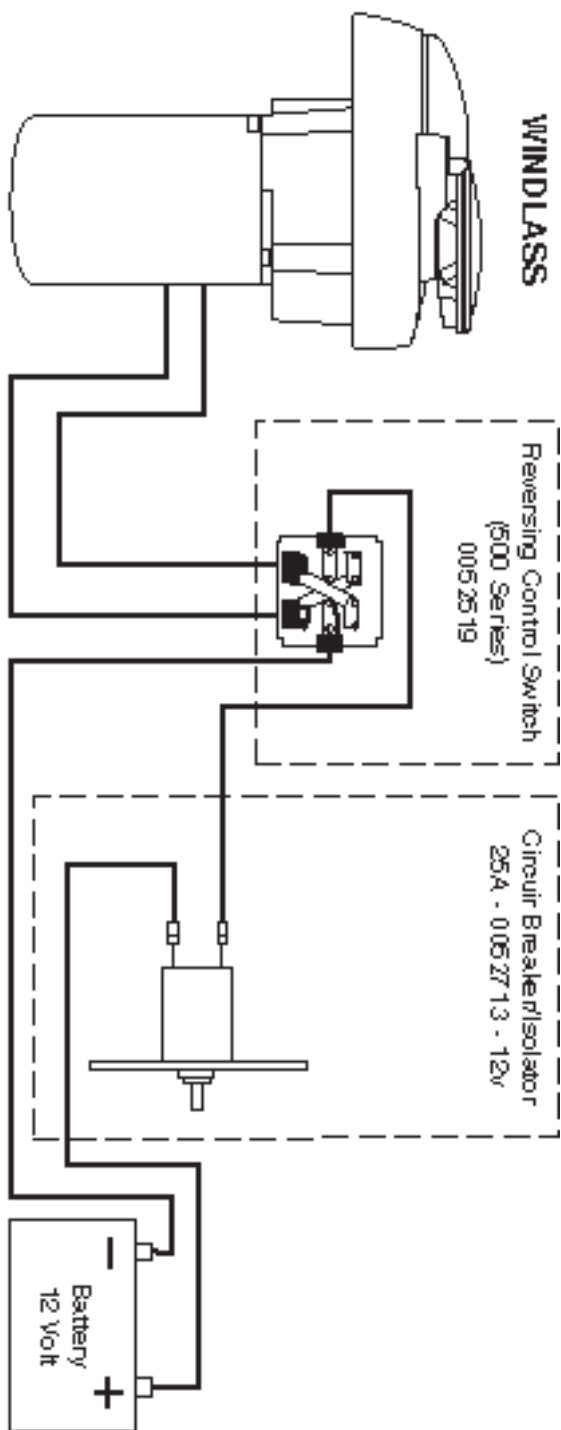

**NOTE:** All installations must be carried out in accordance with USCG, ABYC and NIMA requirements. If you have any questions regarding this installation, contact your nearest Simpson-Lawrence agent.

If the windlass operates in the wrong direction, change over the windlass cable connections at the reversing Control Switch.

**NOTE:** The above switch must never be used in conjunction with other switch gear.

## Failure to Operate

### Troubleshooting Chart: H500 Reversing Control Switch (#0052519)

<p>Is there voltage at the input terminal (positive) to the control switch?</p> <p><b>Yes ↓      No ⇒</b></p>	<p>If no voltage is present the battery isolation switch is <b>off</b>, the breaker is tripped or a fuse has blown. The battery may also have be dead or disconnected.</p>
<p>Check voltage at the output terminals of the control switch with the switch on forward then reverse.</p> <p>Is there voltage at either output terminal for forward then reverse?</p> <p><b>Yes ↓      No ⇒</b></p>	<p>Control switch is defective.</p>
<p>Replace the motor.</p>	

## Sluggish Operation

### Troubleshooting Chart

<p>Is the windlass overloaded?</p> <p><b>Yes ↓      No ⇒</b></p>	<p>Ease the load and ensure the battery is well charged.</p>
<p>Check the voltage across the motor leads with the windlass on. (Proper voltage is 13.5 volts. Constant low voltage will destroy the motor).</p> <p>Is the voltage low? (Below 11.0 volts on a 12 volt system).</p> <p><b>Yes ↓      No ⇒</b></p>	<p>There is a severe voltage drop in the circuit. Check for undersized cables, poor connections or corroded connections. Also check for resistance across the battery isolation switch or solenoid. (Feel them to see if they are heating up).</p>
<p>Is the voltage correct? (Above 11.0 volts and anchor is not fouled).</p> <p><b>Yes ⇒</b></p>	<p>The motor is defective. Replace the motor.</p>

## Multi-Station Installation

### Troubleshooting Chart: Electric Windlass - Failure to Operate

<p>Is there voltage at the input terminals to the solenoids and foot switches?</p> <p><b>Yes</b> ↓     <b>No</b> ⇒</p>	<p>Check the battery isolation switch, circuit breaker, helm console switch and any fuses.</p>
<p>Press the foot switch or operate the remote switch. Is there voltage at the positive switch terminal on the solenoid?</p> <p><b>Yes</b> ↓     <b>No</b> ⇒</p>	<p>The foot switch or remote switch (or its wiring), is defective.</p>
<p>Keep the foot or remote switch activated. Is there voltage at the main output terminal on the solenoid?</p> <p><b>Yes</b> ↓     <b>No</b> ⇒</p>	<p>Check the solenoid coil ground circuit. If okay, replace the solenoid.</p>
<p>Check the voltage at the motor. If voltage is present, the motor is defective. If you have any questions call Simpson-Lawrence.</p>	

## 11. WARRANTY STATEMENT

### **WARRANTY COVERAGE:**

Simpson-Lawrence, USA., warrants to the original purchaser, subject to the limitations and exclusions described below, that this product will be free from defects, in material and workmanship under normal use and service for a period of 1 year from the date of its original sale. Simpson-Lawrence will repair or replace any part, which proves to be defective in normal use during the period of the warranty.

### **WARRANTY CLAIMS PROCEDURES:**

If a defect is discovered during the applicable warranty period, the buyer must promptly notify Simpson-Lawrence of such, in writing, at the nearer address below, providing proof of purchase. For warranty service, the product must be returned to Simpson-Lawrence for examination. This examination will be performed at no charge to the buyer. The buyer is responsible for any labor costs associated with preparing the product or parts for shipping or transporting the products or parts to and from Simpson-Lawrence.

### **REMEDY:**

Simpson-Lawrence will repair any defect in material or workmanship or, at its option, correct such defect by replacing non-conforming goods or parts. Such repairs and/or new parts are warranted for the unexpired portion of the original warranty, or for 90 days, whichever is later. Warranty work (parts and/or labor) shall be at Simpson-Lawrence's expense; however, product preparation and shipping costs to and from Simpson-Lawrence shall be borne by the buyer. These remedies for breach of warranty.

### **LIMITATIONS AND EXCLUSIONS:**

- (1) This warranty applies only if the product is used under non-commercial, normal use in service, and shall not apply to (a) products subject to (i) conditions or usage that exceed the products performance specifications, (ii) incorrect maintenance, or (iii) use in applications for which they were not intended; (b) defects or damage caused by a force which exceed design specifications, including but not limited to, wear and tear, corrosion or ultraviolet degradation; and (c) defects or damages caused by unauthorized attachments, accessories or modifications.
- (2) Simpson Lawrence's warranties of fitness and merchantability, as well as other expressed warranties contained herein, shall apply only to those parts and components manufactured and installed by Simpson Lawrence. Simpson Lawrence reserves the right to alter the products specifications and design without prior notice.

THE FOREGOING WARRANTIES ARE EXCLUSIVE AND IN LIEU OF ALL OTHER EXPRESSED WARRANTIES, IMPLIED WARRANTIES, INCLUDING BUT NOT LIMITED TO THE IMPLIED WARRANTIES OF MERCHANTABILITY AND FITNESS FOR A PARTICULAR PURPOSE, DO NOT EXTEND BEYOND THE DURATION OF THE EXPRESSED WARRANTIES PROVIDED HEREIN.

IN NO CASE SHALL SIMPSON LAWRENCE BE LIABLE FOR ANY SPECIAL, INCIDENTAL OR CONSEQUENTIAL DAMAGES BASED ON BREACH OF WARRANTY, BREACH OF CONTRACT, NEGLIGENCE, STRICT TORT OR ANY OTHER LEGAL THEORY. THIS LIMITATION DOES NOT APPLY TO CLAIMS FOR PERSONAL INJURY.

SOME STATES, OR COUNTRIES, DO NOT ALLOW THE EXCLUSION OR LIMITATION OF INCIDENTAL OR CONSEQUENTIAL DAMAGES OR LIMITATIONS ON HOW LONG AN IMPLIED WARRANTY LASTS, SO THE ABOVE LIMITATIONS OR EXCLUSIONS MAY NOT APPLY TO YOU.

THIS WARRANTY GIVES YOU SPECIFIC LEGAL RIGHTS AND YOU MAY ALSO HAVE OTHER RIGHTS WHICH VARY FROM STATE TO STATE, OR COUNTRY TO COUNTRY.

The models described in this document are subject to a policy of continual improvement. **Simpson-Lawrence Engineering Limited** reserve the right to alter specifications and recommendations without notice. For the latest information regarding any aspect of the windlass please contact your local agent or: -

**Simpson-Lawrence Engineering Limited** Deanside Road  
Hillington  
GLASGOW  
G52 4SZ  
United Kingdom.

Telephone : +44 (0)141 304 8000  
Facsimile : +44 (0)141 304 8001

Customer Support Telephone : +44 (0)141 304 8025  
Facsimile : +44 (0)141 304 8001

**Simpson-Lawrence Limited** 218/228 Edmiston Drive  
Ibroy  
GLASGOW  
G51 2YT  
United Kingdom.

Telephone : +44 (0)141 300 9100  
Facsimile : +44 (0)141 427 5419  
Email : [info@simpson-lawrence.co.uk](mailto:info@simpson-lawrence.co.uk)

Service Division Telephone : +44 (0)141 300 9200  
: +44 (0)141 427 9666  
Facsimile : +44 (0)141 427 5419

**Simpson Lawrence USA Inc.** 6208, 28th Street East  
Bradenton  
FLORIDA  
34203-4123  
United States of America.

Telephone : 1 800 WINDLAS  
: (Toll Free) 1 800 946 3527  
: +1 941 753 7533  
Facsimile : +1 941 746 7166

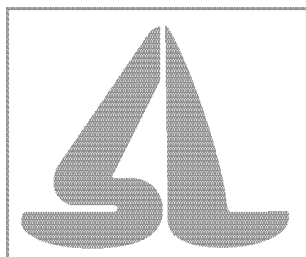

**SIMPSON  
LAWRENCE**

