



1. Windlasses



Reliable
 Motorbox
 Option for quicker
 and less hassle
 Recovery
 IP68
 up to 14m (48ft)

V1/V2/V3 Specifications

MODEL	MOTOR POWER Watt	MAX PULL		WORKING LOAD		MAX LINE SPEED		NORMAL CURRENT DRAW Amp	CIRCUIT BREAKER Amp	APP WEIGHT GYPSY ONLY		APP WEIGHT GYPSY/DRUM	
		kg	lb	kg	lb	m/min	ft/min			kg	lb	kg	lb
V1	700	454	1000	113	250	19	65	80	90	19	42	-	-
V2 12v	700	650	1433	163	358	21	69	80	90	19	42	22	48.5
V2 24v	900	760	1675	180	396	24	79	45	50	19	42	22	48.5
V3 12v	1000	890	1962	215	473	28	92	85	110	21.5	47	24.5	54
V3 24v	1000	1020	2248	243	535	30	98	60	90	21.5	47	24.5	54

V1/V2/V3 Complete Kit - Include Fastfit™ feature

GYPSY ONLY	GYPSY DRUM	MODEL	GYPSY NO- CHAIN DESCRIPTION	VOLTAGE
6671011107-138 (USA Only)	-	V1	000- 7mm ISO 4565, 1/4" G40*, 1/4" BBB	12
6671011108-138 (USA Only)	-	V1	002- 10mm DIN 766, Campbell 3/8" S4, 5/16" G40	12
6671011196-138	-	V1	006- 6mm ISO 4565, 1/4" G40*, 1/4" BBB	12
6671011197-138	-	V1	000- 7mm ISO 4565, 1/4" G40*, 1/4" BBB	12
6671011198-138	-	V1	001- 8mm DIN 766, 8mm ISO 4565	12
6672011196-138	6672021196-138	V2	006- 6mm ISO 4565, 1/4" G40*, 1/4" BBB	12
6672011197-138	6672021197-138	V2	000- 7mm ISO 4565, 1/4" G40*, 1/4" BBB	12
6672011198-138	6672021198-138	V2	001- 8mm DIN 766, 8mm ISO 4565	12
6672011108-138	6672021108-138	V2	002- 10mm DIN 766, Campbell 3/8" S4, 5/16" G40	12
6672011110-138	6672021110-138	V2	003- 10mm ISO, Campbell 3/8" S3, Lewmar 9.5mm G40	12
6672012198-140	6672022198-140	V2	001- 8mm DIN 766, 8mm ISO 4565	24
6672012108-140	6672022108-140	V2	002- 10mm DIN 766, Campbell 3/8" S4, 5/16" G40	24
6672211197-139	6672221197-139	V3	000- 7mm ISO 4565, 1/4" G40*, 1/4" BBB	12
6672211198-139	6672221198-139	V3	001- 8mm DIN 766, 8mm ISO 4565	12
6672211108-139	6672221108-139	V3	002- 10mm DIN 766, Campbell 3/8" S4, 5/16" G40	12
6672211110-139	6672221110-139	V3	003- 10mm ISO, Campbell 3/8" S3, Lewmar 9.5mm G40	12
6672212198-142	6672222198-142	V3	001- 8mm DIN 766, 8mm ISO 4565	24
6672212108-142	6672222108-142	V3	002- 10mm DIN 766, Campbell 3/8" S4, 5/16" G40	24
6672212110-142	6672222110-142	V3	003- 10mm ISO, Campbell 3/8" S3, Lewmar 9.5mm G40	24

Above kits all feature Fastfit™ motor gearboxes

Windlass Kit includes Deck unit, gypsy, Motor gearbox, rocker switch, circuit breaker and contactor

FastFit™ Feature

FastFit™ motor gearbox attachment enable the windlass to be fitted by one man alone.

While the gearbox alignment to the deck unit is critical to a standard installation, the FastFit™ clamping system perfectly align the deck unit and motorgearbox for a perfect fit first time.

- A** FastFit™ enable the motor / gearbox to be rotated and fixed in increments of 45°
- B** To install your windlass, simply fix the deck unit to the deck and then slide the gearbox up the shaft, swing the FastFit™ clamp shut and tighten up the bronze nut.



V1/V2/V3 Vertical Windlasses

Specify your V1/V2/V3

1 Deck Unit

PART NO. (Non FastFit)	PART NO. (FastFit)	DESCRIPTION
69000481	68000951	V1 Gypsy only
69000484	68000828	V2/3 Gypsy only
69000485	68000829	V2/3 Gypsy Drum

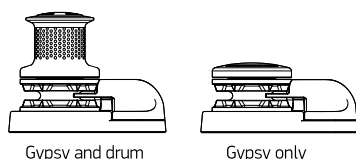

2 Motor Gearbox

PART NO. (Non FastFit)	PART NO. (FastFit)	DESCRIPTION
68001055	66810065	V1-12V
68000527	68000813	V2 - 12V
68000538	68000814	V2 - 24V
66810007	68000815	V3 - 12V
66810008	68000816	V3 - 24V

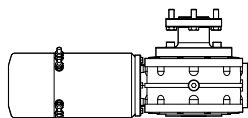

IP68 motor gearbox available (non FastFit™)

- Water resistant unit won't be damaged even if submerged under water
- Robust composite case
- Compression cable clamps included
- No maintenance required
- Provide best motor protection against the elements

3 Gypsy

PART NO.	GYPSY NUMBER	CHAIN DESCRIPTION	ROPE SIZE		ROPE DESCRIPTION
			mm	in	
68000840	006	6mm ISO 4565, 1/4" G40*, 1/4" BBB	12-14	1/2	3-strand and 8-plait
68000360	000	7mm ISO 4565, 1/4" G40*, 1/4" BBB	12-14	1/2	3-strand and 8-plait
68000361	001	8mm DIN 766, 8mm ISO 4565	12-16	1/2 - 5/8	3-strand and 8-plait (5/8 only)
68000362	002	10mm DIN 766, Campbell 3/8" S4, 5/16" G40	12-16	1/2 - 5/8	3-strand and 8-plait (5/8 only)
68000363	003	10mm ISO, Campbell 3/8" S3, Lewmar 9.5mm G40	16	5/8	3-strand and 8-plait

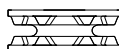

*G40 = Grade 40 Short Link Chain



1. Windlasses

V1/V2/V3 Vertical Windlasses

V1/V2/V3 switch kit and accessories

4 Circuit Breakers



PART NO.	DESCRIPTION	FIT WINDLASS
68000348	Circuit Breaker 50A	V2 24V
68000349	Circuit Breaker 90A	V1/2 12V - V3 24V
68000350	Circuit Breaker 110A	V3 12V - V4/V5 24V
68000351	Circuit Breaker 150A	V4/V5 12V - V6 24V - V8 2.5kW
68000894	Circuit Breaker 200A	V8 3.5kW

5 Contactor



PART NO.	DESCRIPTION	V1	V2/V3
Sealed Contactors			
68000937	Compact Dual 12V	•	•
68000938	Compact Dual 24V		•
68000318	Dual 12V	•	•
68000319	Dual 24V		•
Contactors in Boxes			
68000129	Dual 12V	•	•
68000130	Dual 24V		•

6 Switches & Accessories

Refer to p34-38 for more information



Footswitches

Chain counters



Wireless remote control

7 Optional Accessories



Control arm kit:
66810030



Manual recovery kit
Gypsy only: 66840054
Gypsy/Drum: 66840056



Bulkhead Fitting
3 gland: 68000866



Manual Handle
29140017

Dimensions Diagram

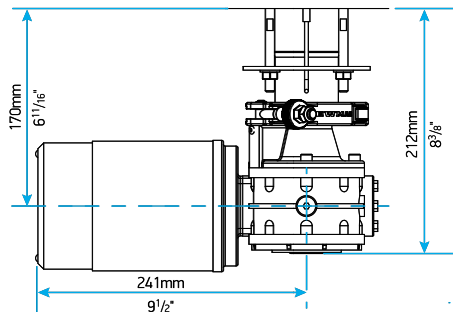
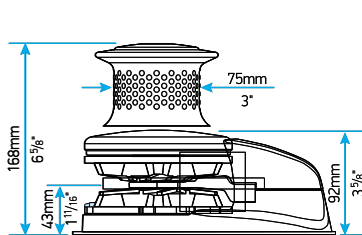

V1 Motor Gearbox
(with FastFit™ feature)

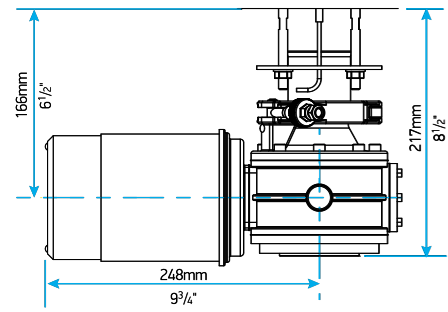

V2/V3 Motor Gearbox
(with FastFit™ feature)

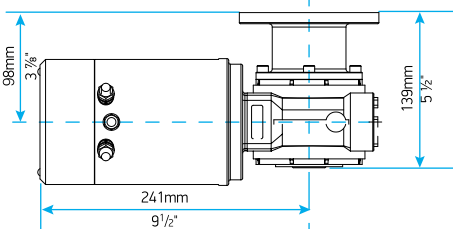
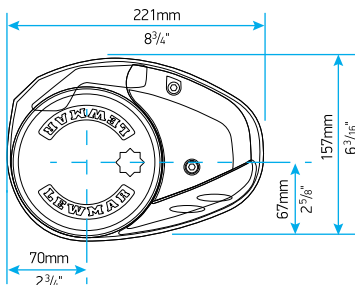

V1 Motor Gearbox
(Non FastFit™)

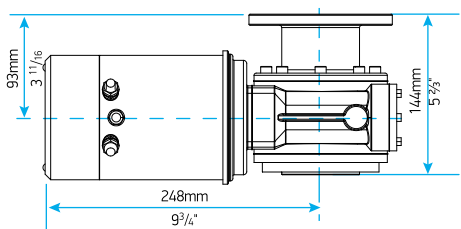

V2/V3 Motor Gearbox
(Non FastFit™)